

# CODEPE SA

INDUSTRIAL FURNACES SWITZERLAND

## BATCH TYPE FURNACE LINE IN MODULAR CONSTRUCTION



- Hardening
- Carburizing
- Carbonitriding
- Quenching (in oil/water/salt)
- Nitriding
- Nitrocarburizing
- Tempering
- Annealing

# CODEPE SA

INDUSTRIAL FURNACES SWITZERLAND

CONSULTING, DEVELOPMENT, RESEARCH AND MANUFACTURE OF INDUSTRIAL FURNACES

LA FENATTE | CH - 2942 ALLE | SWITZERLAND

T +41 32 465 10 10 | F +41 32 465 10 11  
[INFO@CODERE.CH](mailto:INFO@CODERE.CH) | [WWW.CODERE.CH](http://WWW.CODERE.CH)



**SYSTEM 250**



# BATCH TYPE FURNACE LINE

under controlled atmosphere, in modular construction  
No mechanical locking of the charge

# SYSTEM 250

PATENTED

Resuming by hand possible

Treatment programme

Console for programming and visualisation

Control and monitoring system

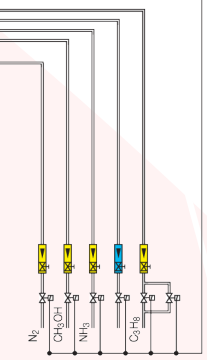
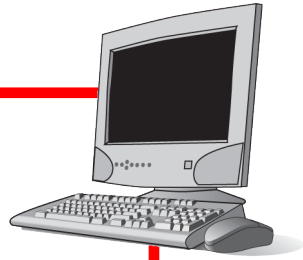
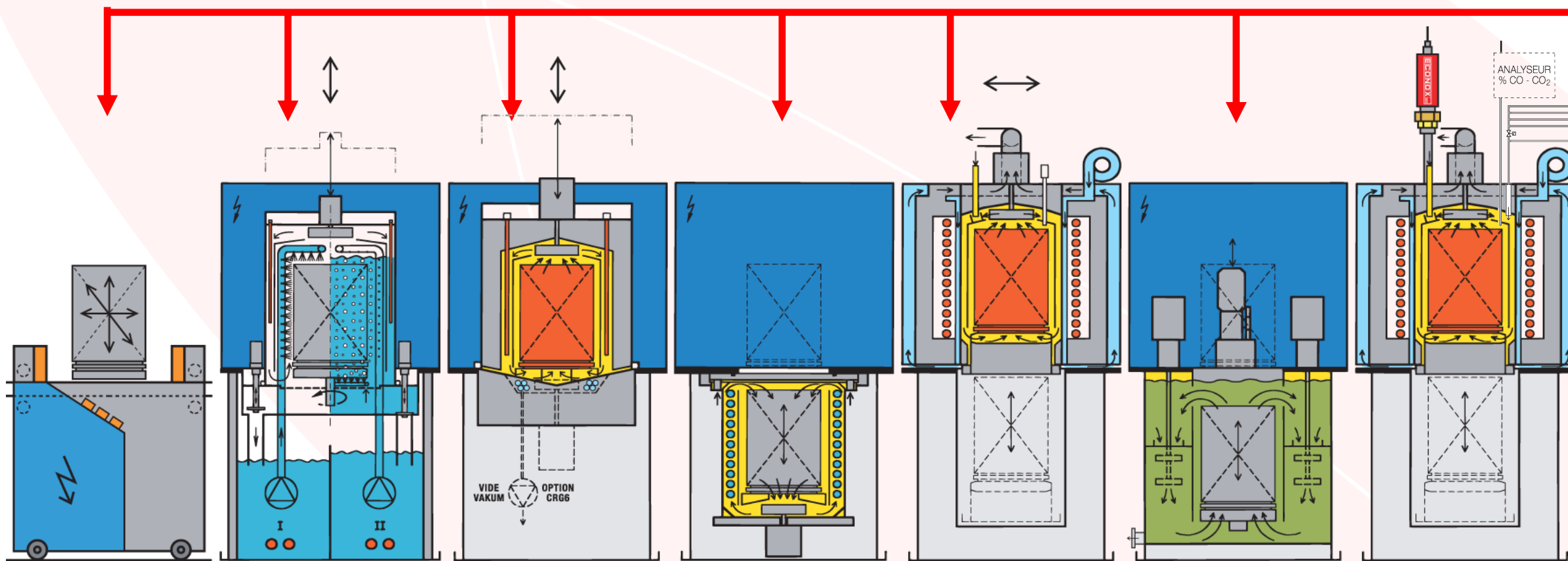

Gas distribution panel

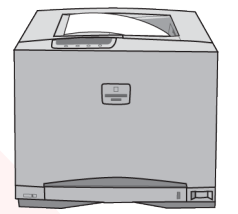

Printing of the heat treatment records

### M - MM - MMM

Manipulator: manually operated, motorized or automatic mode handling by integrated manipulator

### LA2

Alkaline washing 1-2 tanks / 2-3 tanks spraying immersion (flotation) drying (under vacuum)

### CR6 - CRG6

Furnace: with or without protective gas pre-heating, tempering, annealing, nitriding nitrocarburizing 650°C – 850°C with or without cooler

### N2BP - N2HP

Nitrogen or air cooling station 1-5 bars

### CH8 - C10 - C11

Furnace: pre-heating, annealing, austenitizing, carburizing, carbonitriding, nitriding, nitrocarburizing, oxynitriding 1050°C – 1150°C

### E - H1 - H2 - S4

Quenching bath: water polymers oil max. 100°C oil max. 200°C salt max. 450°C

### CH8 - C10 - C11

Furnace: pre-heating, Annealing, austenitizing, carburizing, carbonitriding, nitriding, nitrocarburizing, oxynitriding 1050°C – 1150°C

**Charge transfer by sliding** **PATENTED**

- without locking of the charge
- without mechanism = no breakdown
- without any wear and locking elements
- full gas protection during quenching

## A concept for the future and its advantages

To let the load slide is easier and more reliable than to lock it.

- Half or fully automated operation (automates + monitoring system)
- Change of heat-treatment atmospheres within minutes
- Several temperature ranges (1150°C – 1000°C – 850°C – 650°C)
- Cylindrical tight heat-treatment chamber (very long working life)
- Uniform, intense forced circulation of the furnace atmosphere
- No mechanical locking of charge, no intermediate charge support
- All modules with double jacket, evacuation of exhaust gas at only one point
- Visualization of the running program, the running and registered cycles and of the alarms
- Printing of the production records
- The installation is operated by only one person, reproducibility of the heat treatments
- Great flexibility when changing temperatures, forced gas circulation through the charge

- Space-saving dimensions, reduced height, no special foundation necessary
- Modular system. Numerous installation combinations according to requirements
- High uniformity of temperature ( $\pm 3^\circ\text{C}$ ) and carbon potential ( $\pm 0.05\%$ )
- More operation safety, round or square charges
- Simple handling, preparation ramp and transfer table
- Less distortion, less allowance for machining, homogeneous hardness
- Computerized monitoring
- In case of breakdown of a module, the other modules are fully operational
- Modular line with expansion possibilities
- Production doubling by adding a new module
- Possibility of integration into a production line

## SYSTEM 250

PATENTED

Technical data	units	ø 30/35	ø 42/60	ø 42/100	ø 70/60	ø 70/100	ø 90/60	ø 90/100	ø 90/150	ø 110/100	ø 110/150	ø 200/330
Charge												
Maximum charge (gross weight)	kg	30	150	250	350	500	600	1000	1000	1000	1500	3000
Outside diameter	mm	300	430	430	710	710	920	920	920	1120	1120	2000
Effective height	mm	400	650	1050	670	1070	690	1090	1590	1090	1590	3300
Charge volume	dm <sup>3</sup>	25	80	140	220	360	380	630	960	950	1400	9500

Electric heating and/or Gas heating available - Other dimensions on request

